

## Technical data

	operation when directly connected to chimney		operation when connected accumulation mass	
	cupola	hot air exchanger	cupola	adaptor
Energy label	<b>A+</b>	<b>A+</b>	<b>A+</b>	<b>A+</b>
<b>Operating data</b>				
Nominal heat power	8 kW	12 kW	----	----
Efficiency	> 80 %	> 80 %	----	----
Consumption of wood	2,4 kg/h	3,7 kg/h	5,5 kg	5,5 kg
Total heat output of the burning chamber	----	----	22 kW	22 kW
Average heat output / heat accumulation time <sup>5</sup>	----	----	2,2 kW / 8 h	2,2 kW / 8 h
Mass flow of flue gas	8 g/s	11 g/s	20 g/s	20 g/s
Required chimney pressure	12 Pa	12 Pa	12 Pa	15 Pa
Required amount of combustion air	25 m <sup>3</sup> /h	35 m <sup>3</sup> /h	50 m <sup>3</sup> /h	50 m <sup>3</sup> /h
<b>Average flue gas temperature</b>				
on the output	230 °C	275 °C	386 °C	392 °C
behind 3,6 m of ceramic accumulation system KMS 300 <sup>1</sup>	----	----	183 °C	----
behind accumulation rings (5x acc. ring Ø440mm)	----	----	----	229 °C
<b>Heat distribution</b>				
fireplace insert	62–80 %	62–80 %	40 %	35 %
door glass (single / double)	38 / 20 %	38 / 20 %	38 / 20 %	38 / 20 %
additional accumulation mass	----	----	22–40 %	30–45 %
<b>Information for ventilated builds</b>				
Minimal grill area supply / outgoing	900 / 1050 cm <sup>2</sup>	1200 / 1400 cm <sup>2</sup>	1200 / 1400 cm <sup>2</sup>	1200 / 1400 cm <sup>2</sup>
Minimum distance from insulated areas / floor	80 / 0 mm		80 / 0 mm	
Reference insulation <sup>2</sup> ceiling / back wall / side wall / floor	140 / 100 / 100 / 0 mm		140 / 100 / 100 / 0 mm	
Calciumsilicate insulation <sup>3</sup> ceiling / back wall / side wall / floor	110 / 80 / 80 / 0 mm		110 / 80 / 80 / 0 mm	
<b>Information for non-ventilated builds (closed grills)</b>				
Minimum radiant area <sup>4</sup>	suitable		4,5 m <sup>2</sup>	
Minimum distance from insulated areas / floor	80 / 20 mm		80 / 20 mm	
Reference insulation <sup>2</sup> ceiling / back wall / side wall / floor	190 / 140 / 140 / 20 mm		190 / 140 / 140 / 20 mm	
Calciumsilicate insulation <sup>3</sup> ceiling / back wall / side wall / floor	140 / 110 / 110 / 20 mm		140 / 110 / 110 / 20 mm	
<b>General technical information</b>				
Total weight / lining weight	circa 340 / 113 kg		circa 340 / 113 kg	
Burning chamber dimensions (width x depth)	705 x 305 mm			
Combustion air connection	Ø 125 mm			
Use in non-ventilated accumulation builds according to craft rules	suitable			
Tested according to	EN 13229			
Meets values	1. BlmSchV (Stufe2), 15a BVG, NS 3059			

1 Listed value from testing. For accurate results is evaluation of each system in the Ortnr / KOV program necessary

2 Mineral wool according to AGI-Q 132

3 Example SkamoEnclosure Board 225 kg/m<sup>3</sup>

4 Depends on accumulation period and material characteristics. Listed values calculated with average specific heat output = approx. 500 W/m<sup>2</sup>

5 Storage operation, one wood charge for storage duration, with closed construction and efficiency > 80%

# HAKA 78/57h

Technical data  
Version 09/2023

## HAKA 78/57h liftdoor hot air exchanger vertical / smoke outlet 45°

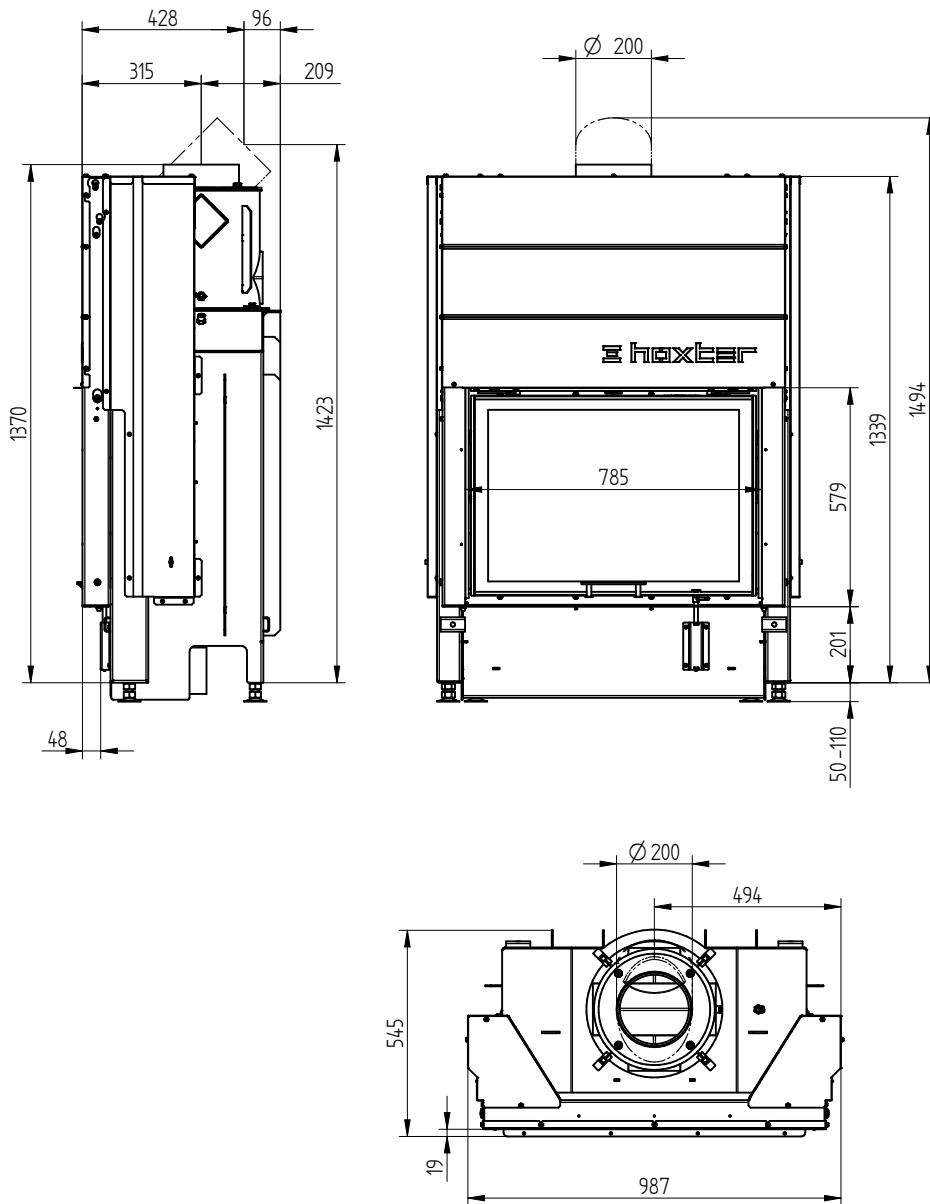

# HAKA 78/57h

Technical data  
Version 09/2023

## HAKA 78/57h liftdoor cupola

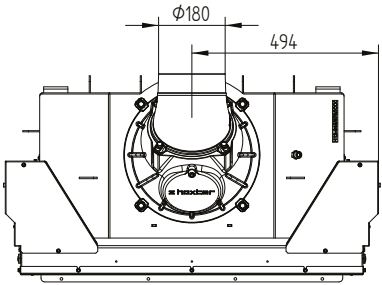
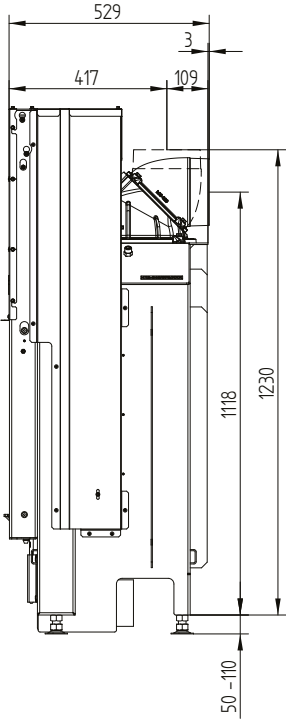

## HAKA 78/57h liftdoor accumulation set

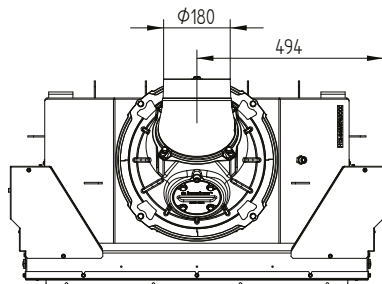
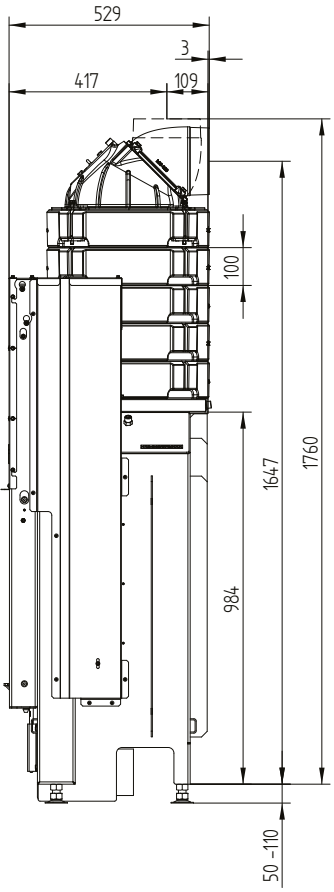

# HAKA 78/57h

Technical data  
Version 09/2023

## Cover frame 78/57h liftdoor 4sides 50 mm 1 x 90° / air inlet

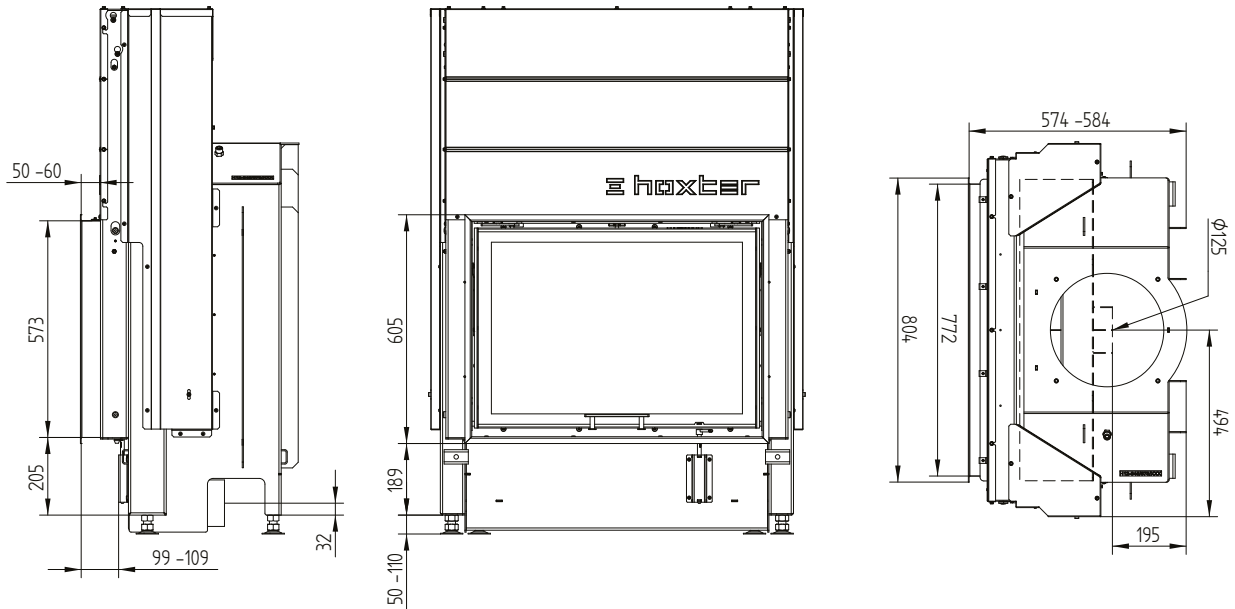

## Cover frame 78/57h liftdoor 4sides 80 mm 1 x 90°

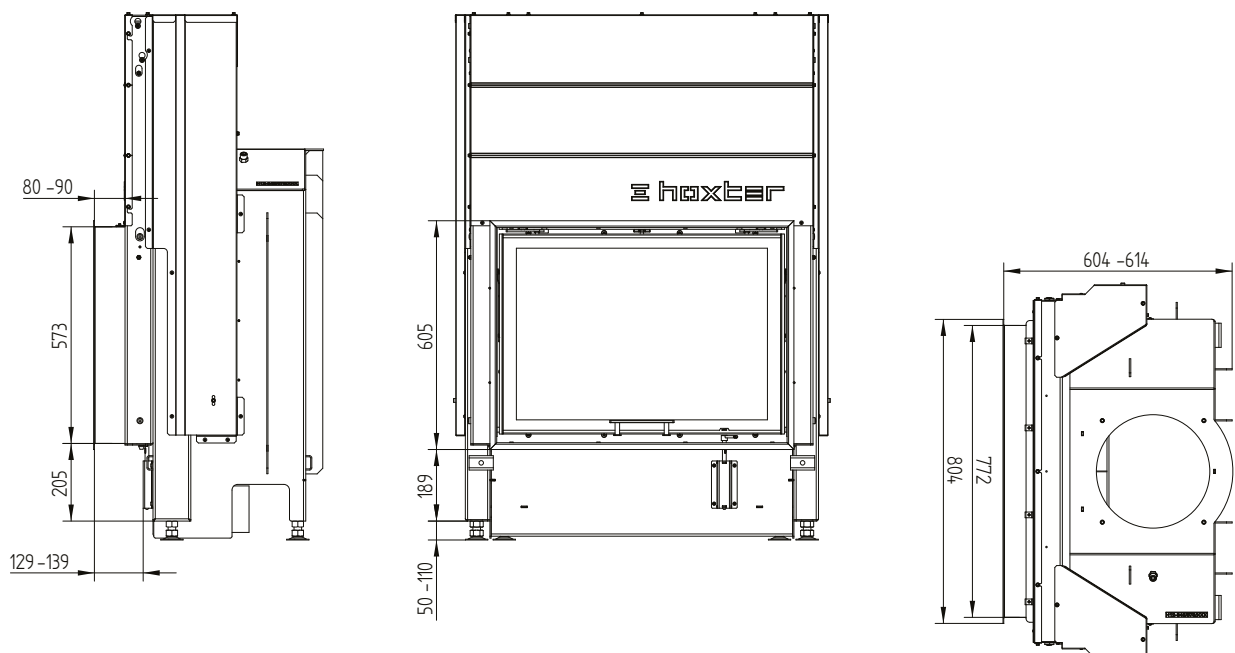

# HAKA 78/57h

Technical data  
Version 09/2023

## Build-on frame 78/57h liftdoor 4sides 50 mm

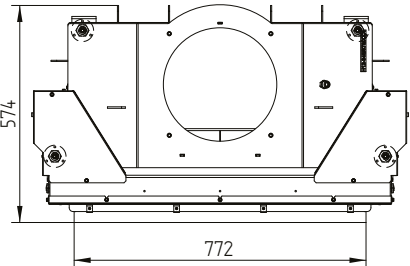
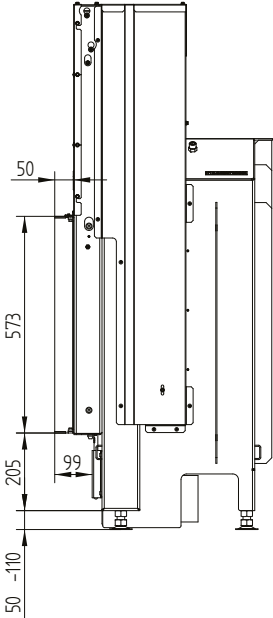

## Build-on frame 78/57h liftdoor 4sides 80 mm / feet

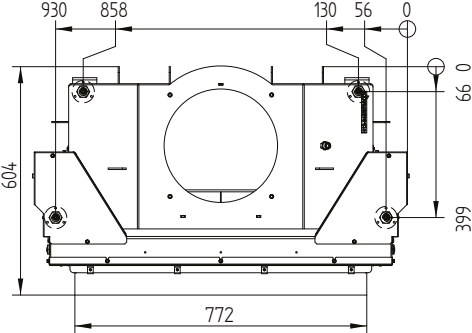
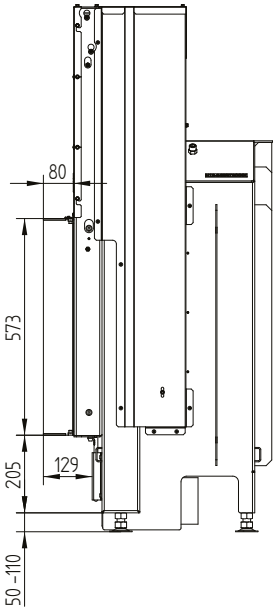

## Build-on frame 78/57h liftdoor 3sides 80 mm

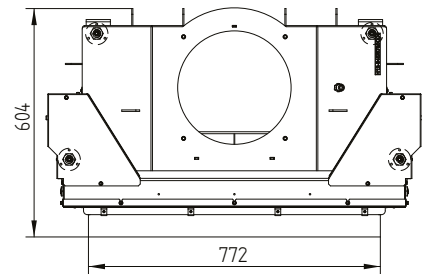
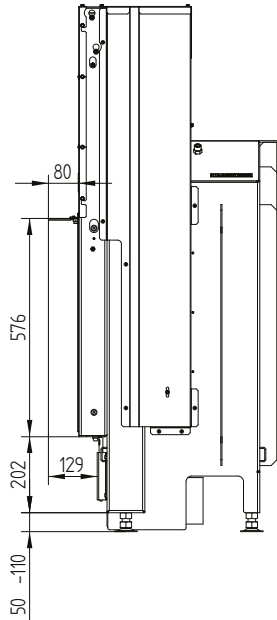

## Convection jacket HAKA 78/57h liftdoor hot air exchanger vertical

